

PRODUCT FEATURES

- Available with centerline or diagonal bolt pattern.
- Lightweight.
- High top-load strength.
- Reduced side draft easier to adjust to grade.
- Nestable for storage or shipping.
- U.V. stable for longer life.
- Stainless steel hardware hex head or penta head bolt.

STOCK COVER IDENTIFICATIONS

- Irrigation control valve (ICV)
- Water (solid or meter door)
- Electric (green or gray)
- Reclaimed water (green or lavender)
- Blank (no cover marking)
- Sewer
- RCV
- CATV
- Telephone
- Street lighting

When ordering, please specify color, cover identification, and bolt down type. For use in non-vehicle traffic areas. Not recommended for installation in concrete or asphalt without felt expansion joint.

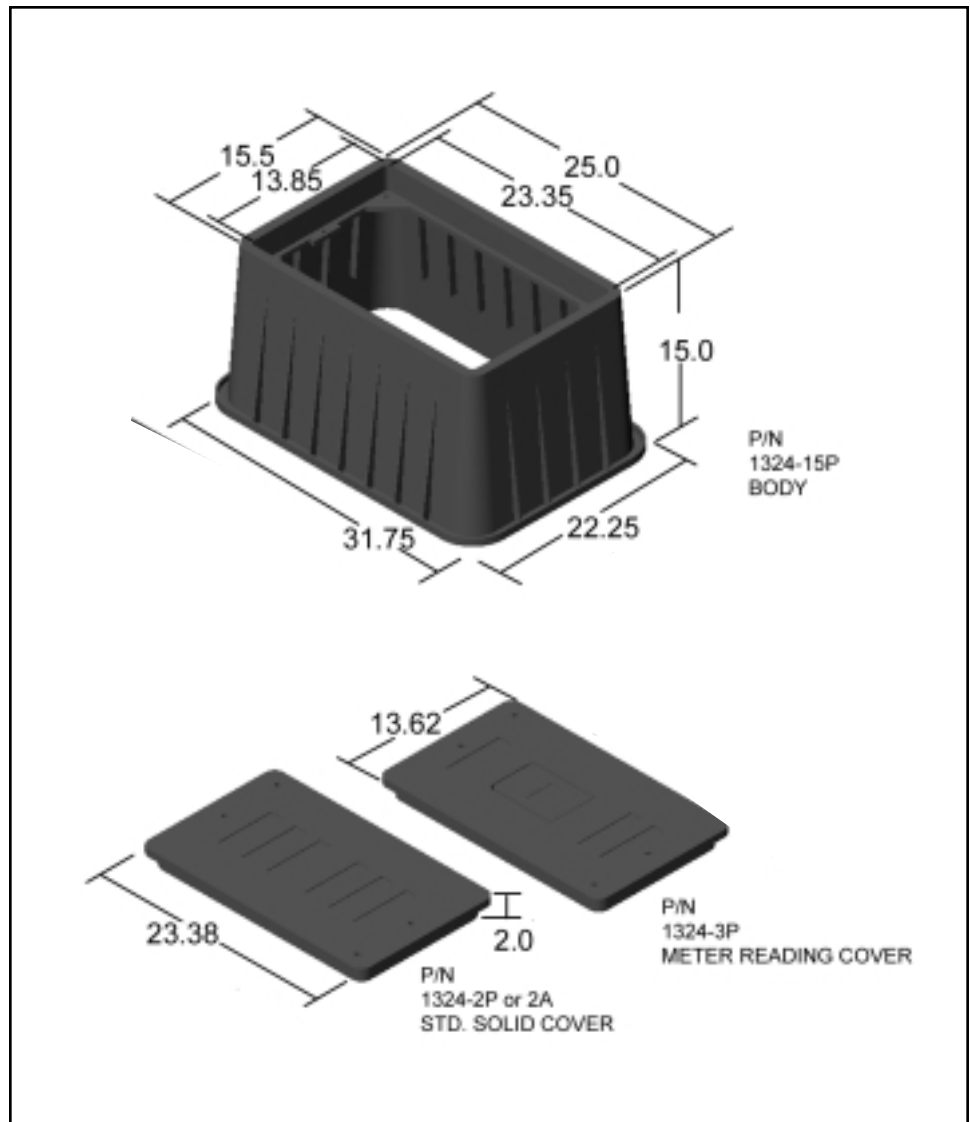

15" UTILITY BOX • 16 per pallet

Catalog Number	Description	Weight
1324-15P2P	15" Body, with Poly Cover	25.4 Lbs.
1324-15P2A	15" Body, with ABS Cover	23.7 Lbs.
1324-15P3P	15" Body, with Poly Meter Reader Cover	25.4 Lbs.
1324-15P	15" Body	19.3 Lbs.
1324-2P	Poly Cover	6.1 Lbs.
1324-2A	ABS Cover	6.4 Lbs.
1324-3P	Meter Reading Cover	6.1 Lbs.