

# Box Pads for Transformers

## PRODUCT FEATURES

- Constructed of fire-retardant materials. Combination of chopped glass spray-up and hand lay-up of woven roving glass reinforcement.
- External ribs are molded into all sides for greater side-wall and vertical strength.
- Heavy-duty reinforced fiberglass construction, stress areas strengthened with nonhydroscopic laminated reinforcing materials.
- Permanent stacking blocks molded in each unit to assure non-binding stacking.
- Gel-coated exterior for superior protection against UV radiation and corrosion resistance.
- Meets or exceeds the Industry Standards:
  - ANSI C57.12.28-1988 Enclosure Integrity.
  - NEUC Guideline 9001-87R1 testing requirements-specified models.
- Exterior color: Munsell #7GY3.29/1.5 Green.

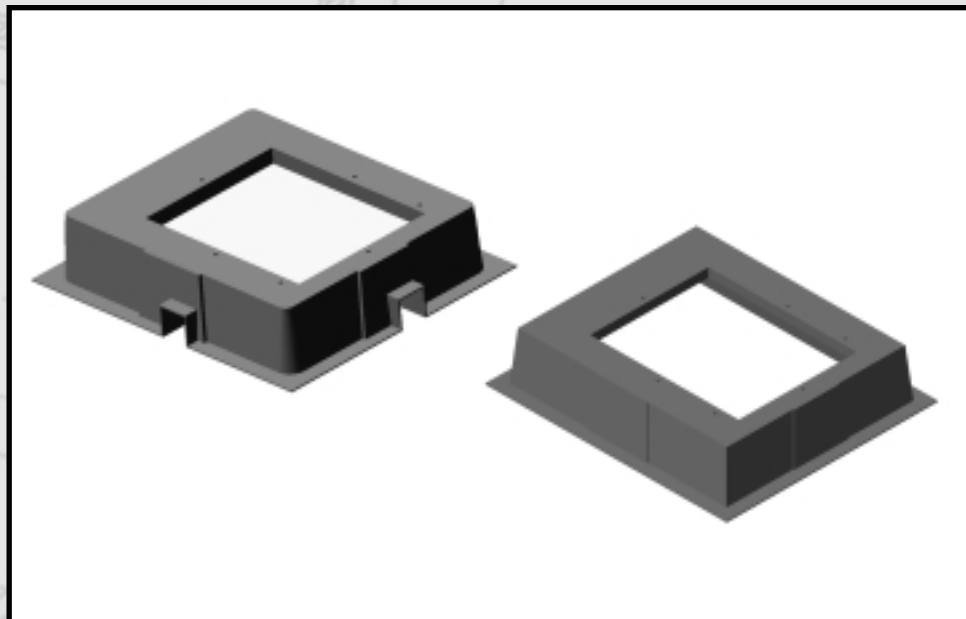
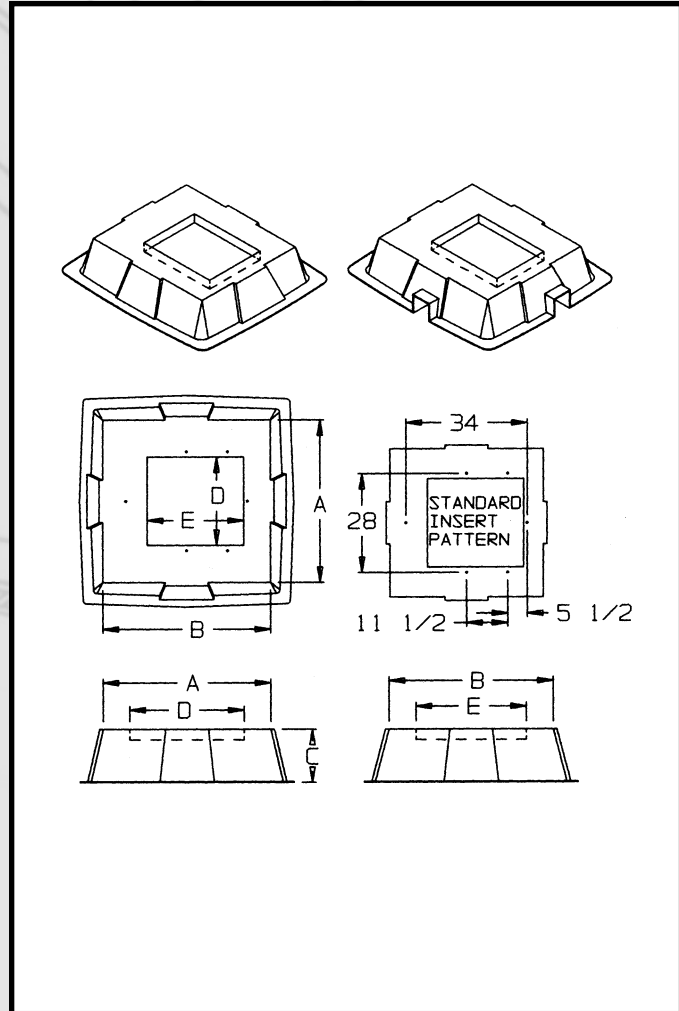

# (4" to 20" FBP Series)

(4" to 15" FBP Series)

	<b>A</b>	<b>B</b>	<b>C</b>	<b>D x E = TOP</b>
<b>Model Number:</b>	<b>Length</b>	<b>Width</b>	<b>Height</b>	<b>Openings</b>
FBP 37-43-04 BF	37	43	4	12 x 26
FBP 62-58-04 RH	62	58	4	44 x 20
FBP 42-42-05 AB	42	42	5	8 x 30
FBP 42-42-05 BE	42	42	5	12 x 20
FBP 48-48-05 KJ	48	48	5	25 x 12
FBP 74-62-05 WY	74	62	5	62 x 12
FBP 48-48-10 IK	48	48	10	22 x 24
FBP 94-70-10 QO	94	70	10	36 x 72
FBP 34-34-15 CZ	34	34	15	18 x 20
FBP 37-37-15 BG	37	37	15	12 x 21
FBP 37-37-15 JJ	37	37	15	22 x 22
FBP 37-43-15 BG*	37	43	15	12 x 21
FBP 37-43-15 BN*	37	43	15	14 x 24
FBP 37-43-15 HH*	37	43	15	20 x 20
FBP 37-43-15 IK*	37	43	15	22 x 24
FBP 37-43-15 IKT*	37	43	15	22 x 24
FBP 37-43-15 KL*	37	43	15	26 x 24
FBP 37-43-15 MD*	37	43	15	26 x 12
FBP 37-43-15 MO*	37	43	15	26 x 32
FBP 40-44-15 EL	40	44	15	18 x 26
FBP 42-48-15 IK	42	48	15	22 x 24
FBP 48-48-15 NN	48	48	15	30 x 30

(16" to 20" FBP Series)

	<b>A</b>	<b>B</b>	<b>C</b>	<b>D x E = TOP</b>
<b>Model Number:</b>	<b>Length</b>	<b>Width</b>	<b>Height</b>	<b>Openings</b>
FBP 42-48-16 BF	42	48	16	12 x 26
FBP 25-40-18 BD	25	40	18	12 x 16
FBP 42-48-20 (PACIF)	42	48	20	26 x 26
FBP 94-70-20 VP	94	70	20	72 x 15
FBP 114-72-20 VP	114	72	20	90 x 17 1/2

\*Comes with standard insert pattern with 3/8-16 UNC stainless steel inserts. Other units can be drilled and inserted upon request. A special suffix can be added to end of part number to comply with special customer specifications. Other sizes available, please consult factory.

Additional sizes and opening available in compression molded units. See pages 2-7.